

Mod. 300S - 310S - 320S



F. Maietti S.r.l.

F.lli MAIETTI s.r.l.
CAT. IV - G.FLUIDO I-II
CE 0100

ROBINETTERIE E VALVOLAME PER IMPIANTI INDUSTRIALI
Via Priv. Salvo d'Acquisto, 16 - 20152 Milano - Tel. 02.47994242 - Fax 02.48910553
Cod. Fisc. e P. IVA 09631210151 - C.C.I.A.A. 1306645 - Trib. Milano Reg. Soc. 262061

Valvola di sicurezza a Molla, Flangiata Spring Safety Valve, Flanged

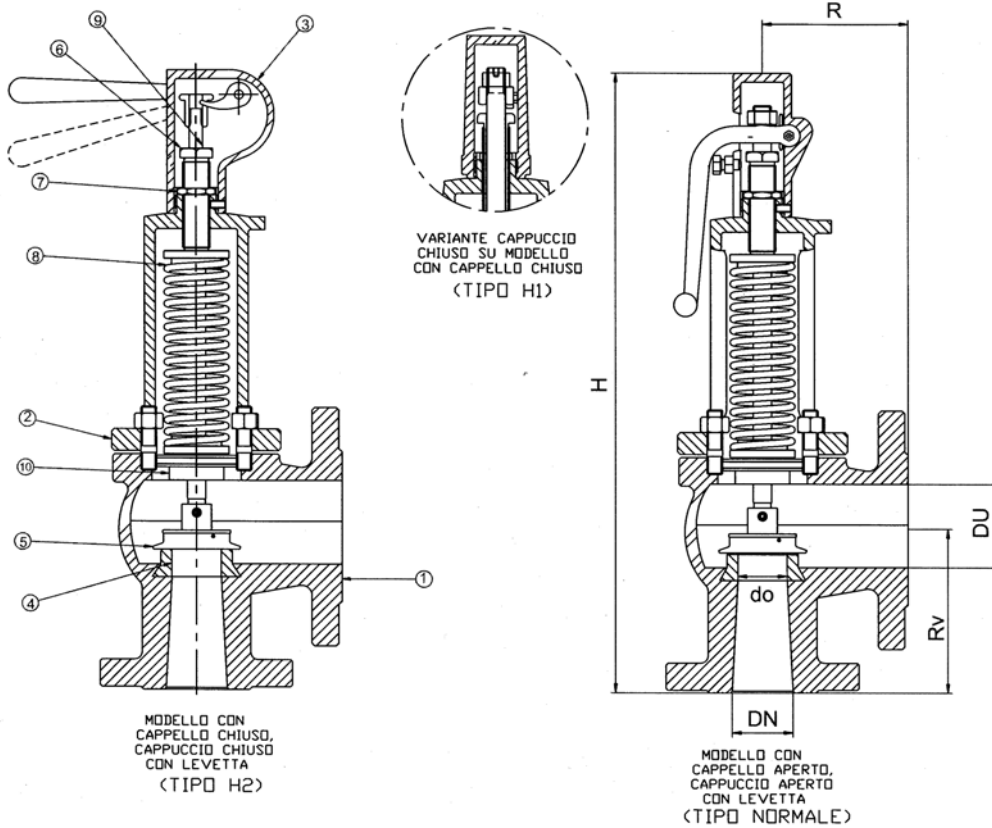

POS.	DESCRIZIONE - DESCRIPTION	MATERIALI - MATERIALS		
		GHISA SFEROIDALE CAST IRON SPHEROIDAL	ACCIAIO CARBON STEEL	ACC. INOX STAINLESS STEEL
		UNI EN GJS 400.15	ASTM A 216 WCB	ASTM A 351 CF8M
		MOD. 300S	MOD. 310S	MOD. 320S
1	CORPO BODY	GHISA GJS 400,15	ASTM A 216 WCB	ASTM A 351 CF8M
2	CAPPELLO BONNET	UNI EN GJS 400,15	ASTM A 216 WCB	ASTM A 351 CF8M
3	CAPPUCCIO CLOSE FITTING	UNI EN 1561 GJL250	UNI EN 1561 GJL250	ASTM A 351 CF8M
4	SEDE SEAT	AISI 316	AISI 316	AISI 316
5	OTTURATORE SHUTTER / DISC	AISI 316	AISI 316	AISI 316
6	VITE REGISTRO REGISTER SCREW	OT. 58/Aisi 316	OT. 58/Aisi 316	AISI 316
7	DADO ESAGONALE HEXAGONAL NUT	OT. 58/Aisi 316	OT. 58/Aisi 316	AISI 316
8	MOLLA SPRING	Acciaio Armonico	Acciaio Armonico	AISI 316 (Max DN.10 mm)
9	ASTA ROD	AISI 304/316	AISI 304/316	AISI 316
10	PIATTELLO GUIDA PLATE	OT. 58/Aisi 316	OT. 58/Aisi 316	AISI 316

DN	DU	do	Area cm ²	Alzata mm	R	Rv	H	H1	H2	Coeff. K Liquidi	Coeff. K
25	32	18	2,54	7,5	98	90	405	360	430	0,55	0,80
32	40	23	4,15	9	101	106	420	373	440	0,55	0,80
40	50	30	7,06	12	111	116	440	395	465	0,55	0,80
50	65	38	11,33	14	111	125	490	448	518	0,55	0,80
65	80	47	17,34	19	121	132	590	565	610	0,55	0,80
80	100	61	29,20	27	148	160	695	640	705	0,55	0,80
100	125	74	42,98	26	160	190	780	750	795	0,55	0,80
125	150	93	67,89	34	190	220	970			0,55	0,80